

'One Trip' Shipping Containers

Size: 20ft x 8ft

Colour: Dark Green (RAL 6007)



Optional Extras

- High security padlock
- Shelving & racking
- Electrics & lighting
- Lining & insulation
- Extra ventilation
- Re-painting specific colours

Information:

- NEW - One Trip Only
- CSC plated (gross weight) max: 30 ton
- All 'Cor-Ten Steel' construction
- Exterior hinged double doors at end
- Two locking bars on EACH door
- Factory fitted lockbox
- 2 x forklift pockets on each side
- 28mm Marine Plywood floor on steel cross members
- 4 Vents

Dimensions & Weights

External Length: 6.06m / 19ft 10in	External Height: 2.6m / 8ft 6in	External Width: 2.44m / 8ft	Door Width: 2.34m / 7ft 8in
Internal Length: 5.9m / 19ft 4in	Internal Height: 2.39m / 7ft 10in	Internal Width: 2.35m / 7ft 8in	Door Height: 2.28m / 7ft 5in

Cubic capacity	33.1 cubic metres / 1170 cubic feet
Max gross weight	30480kg / 67200lbs
Tare weight	2230kg / 4920lbs



portablespace

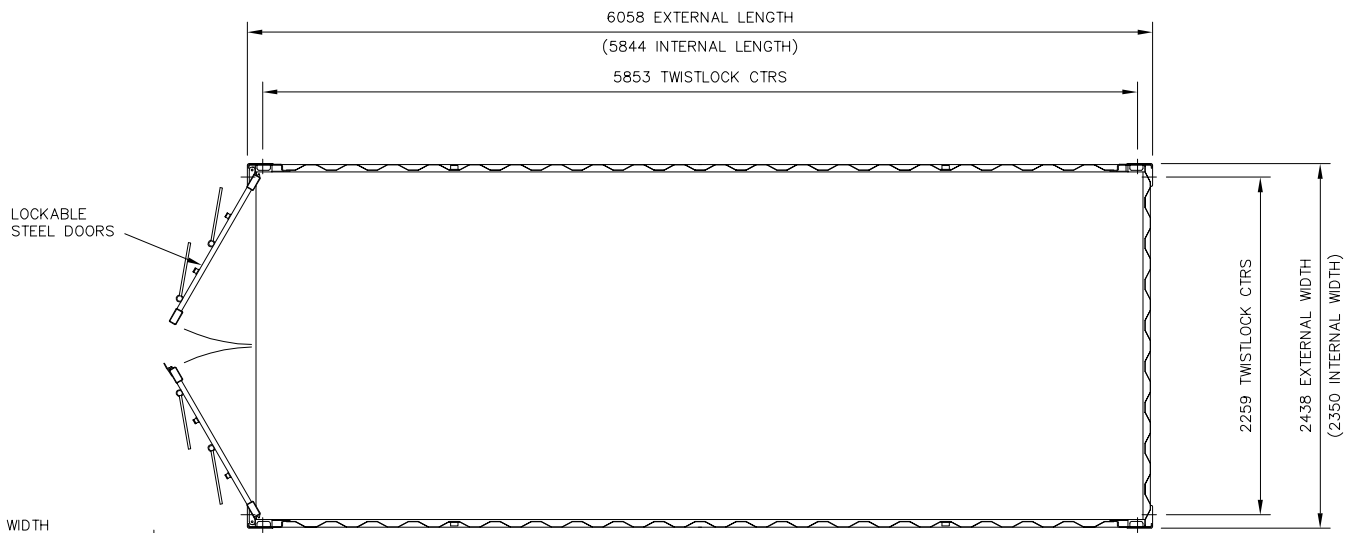

SECTIONAL PLAN

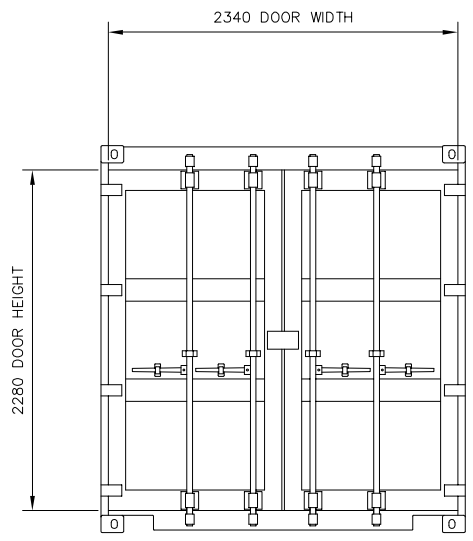

END ELEVATION

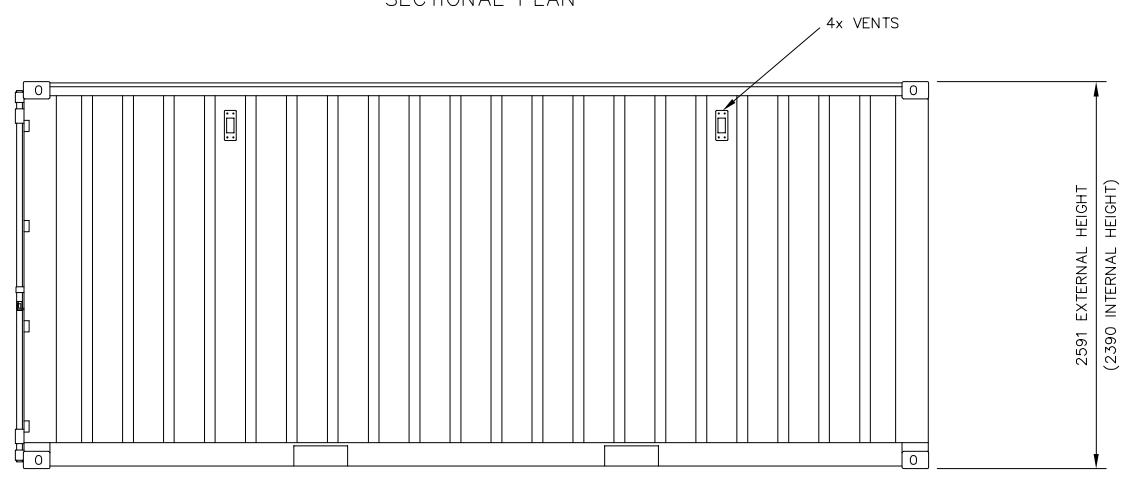

SIDE ELEVATION

- DISTRIBUTION BOARD
- CONVECTOR HEATER
- TUBULAR HEATER
- HIGH LEVEL FAN HEATER
- FLUORESCENT LIGHT
- BULKHEAD LIGHT
- WATER HEATER
- 13A TWIN SOCKET - LOW
- 13A TWIN SOCKET - HIGH
- WALL LIGHT SWITCH
- PULL LIGHT SWITCH
- THERMOSTAT
- EXTRACTION FAN
- COOKER POINT
- SHOWER HEATER
- COAT HOOKS
- SLIDING WINDOW COMPLETE WITH SHUTTER
- HL HIGH LEVEL
- TOV TOP OPENING VENT
- WT WORKTOP
- ML MORTICE LOCK
- BL BATHROOM LOCK
- DL5 5 LEVER DEADLOCK
- RL ROLLER LATCH
- BB BARREL BOLTS
- FROST STAT
- VENT

UNLADEN WEIGHT (KG)	
MAXIMUM LADEN WEIGHT (KG)	
MAXIMUM LIFT WEIGHT (KG)	

DRAWING STATUS		COLOUR		Project	
1	<input checked="" type="checkbox"/> PRELIMINARY FOR INFORMATION ONLY	OVERALL CAPACITY (M3)	32.8	20' X 8' CONTAINER	
2	<input type="checkbox"/> ISSUED FOR APPROVAL			Title	
3	<input type="checkbox"/> CLIENT APPROVED	Product Code		PLAN LAYOUT	
4	<input type="checkbox"/> ISSUED FOR CONSTRUCTION	Date		Scale	Drawn By
5	<input type="checkbox"/> AS BUILT	21-04-08		1 : 50	S.J.B
6	<input type="checkbox"/>	Drawing No.		Rev.	
				516	