

NOTES
 1. FIXED SINGLE AXLE RUBBER BEAM UNIT
 2. LINED & INSULATED IN PLASTISOL PANELS
 3. EKO PLY PLASTIC FLOORING

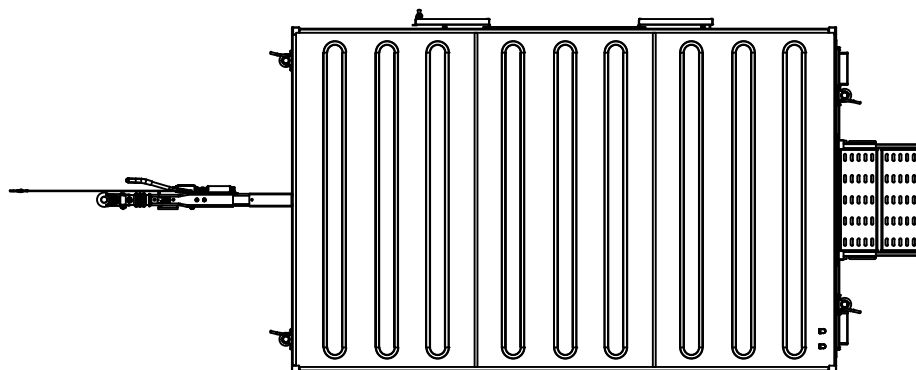
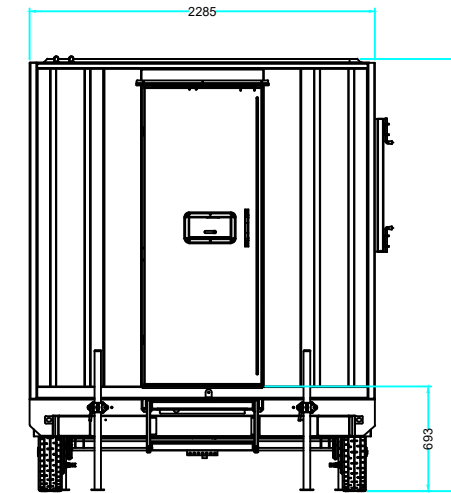
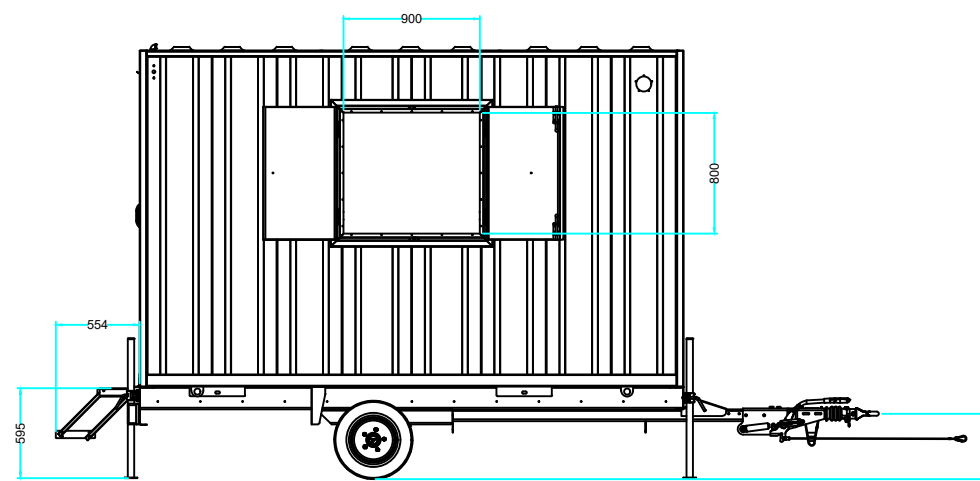
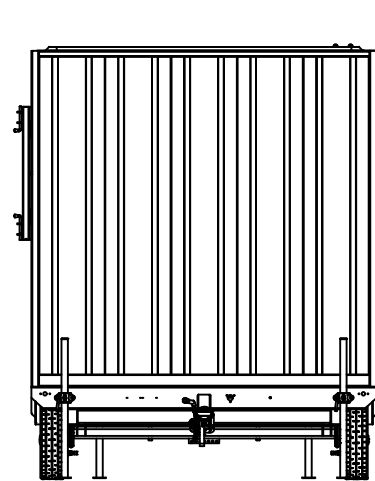
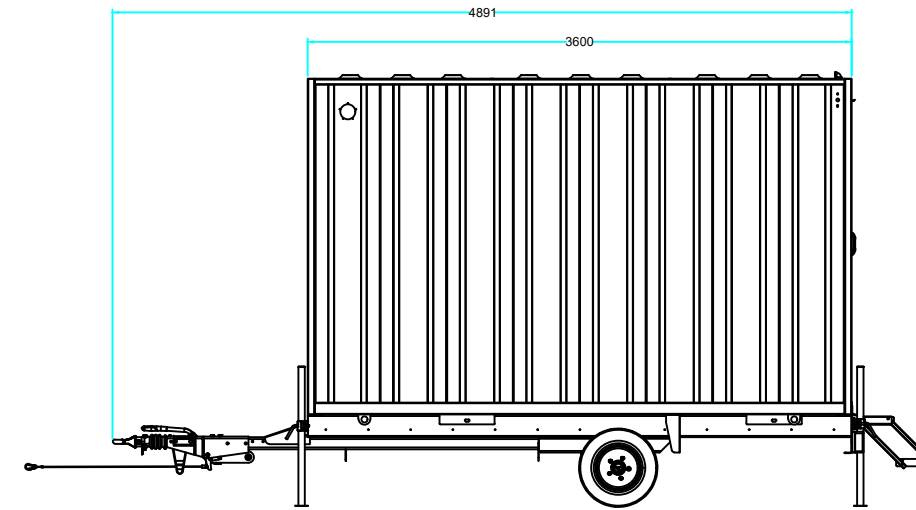
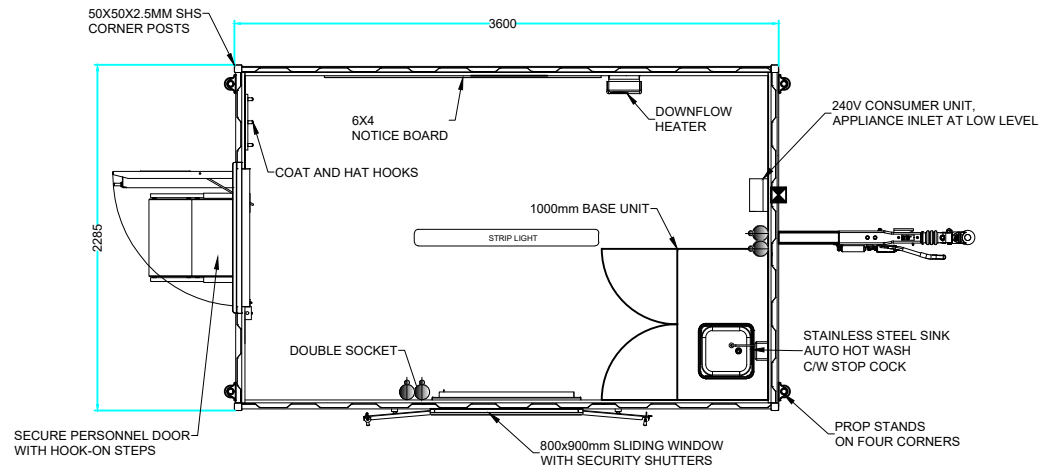

portablespace[®]
 cabin & container hire | sales | conversions | modular

Red House Farm Business Units, Bacton, Suffolk, IP14 4LE
 TEL. 01449 782 123 www.portalspace.co.uk

Copyright in this drawing belongs to Portable Space Ltd. Neither the whole drawing nor any part thereof may be reproduced without the prior written permission of Portable Space Ltd.

DESCRIPTION: 12FT X 7FT 6IN MOBILE CANTEEN		QF NUMBER: QF-215	
CONTAINER TYPE: MOBILE WELFARE UNIT		DRAWING NUMBER: 10-10215	Rev: A
DRAWN BY J.M.	DATE 23/11/2023	UNLESS OTHERWISE SPECIFIED, DIMENSIONS ARE IN MILLIMETERS TOLERANCES (UNLESS OTHERWISE SPECIFIED): LINEAR = 0 +/- 2.0mm 0.0 +/- 1.5mm 0.00 +/- 0.50mm ANGULAR = 2deg	
CHECKED BY I.S.	DATE 28/11/2023		
SCALE: 1:50		[DO NOT SCALE DRAWING]	A3
WEIGHT: 1,450kg (APPROX. CALCULATION)		SHEET 1 OF 1	