

ISO VIEW
[SCALE 1:50]

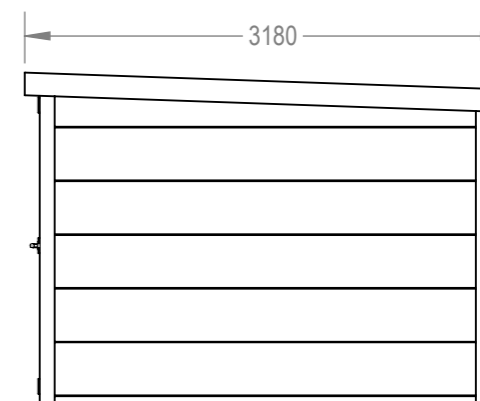

BUILD NOTES:

- AVAILABLE FINISHES; ANTHRACITE [RAL7043]
- WINDOW & DOOR LOCATIONS CUSTOMISABLE
- INSULATED SANDWICH ROOF PANELS 40MM - OPTION TO ADD INSULATION TO WALLS (UP TO 80MM)
- DOOR EQUIPPED WITH OPAQUE PLEXI GLASS & CYLINDER LOCK
- EAVES AND THE DOOR ARE IN ANTHRACITE
- UNDERSIDE OF ROOF IN WHITE
- EXTERNAL SHEETS CONSTRUCTED FROM 0.9mm HOT-DIPPED GALVANISED STEEL
- ROOF DESIGNED WITH PITCH OF 2°
- INTEGRATED GUTTER WITH DOWNPIPE Ø60MM OUTLET
- FLOOR NOT INCLUDED

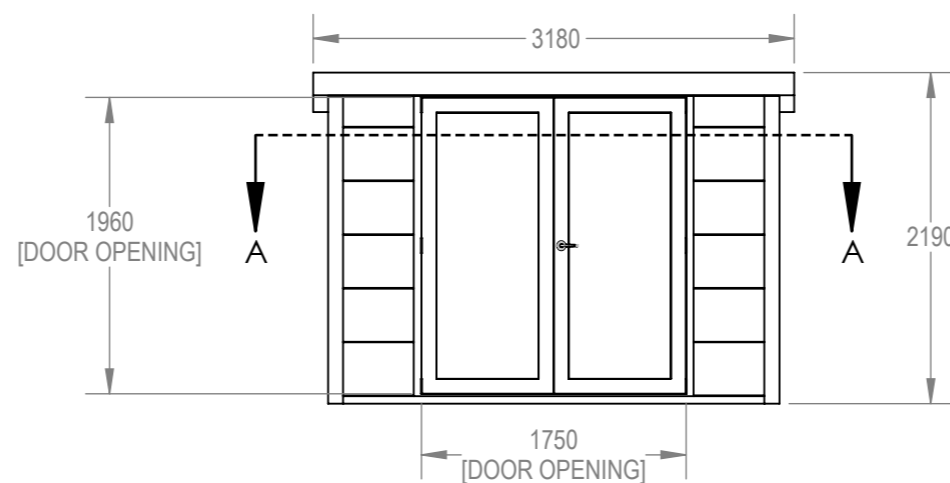
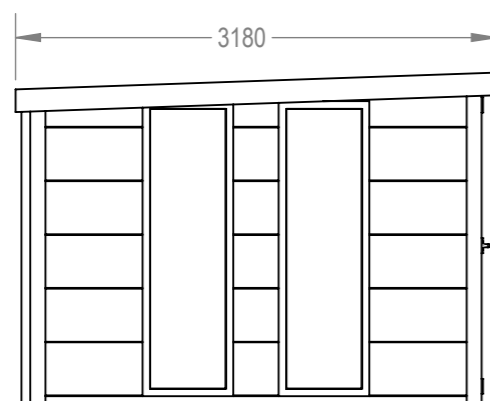
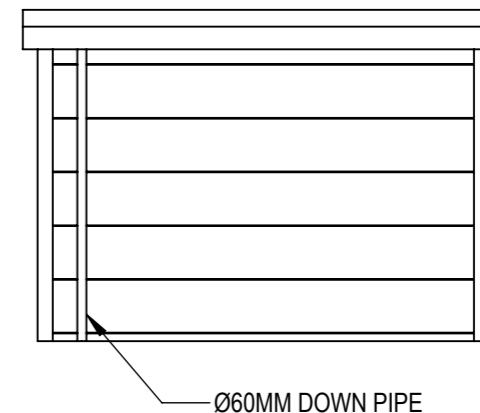
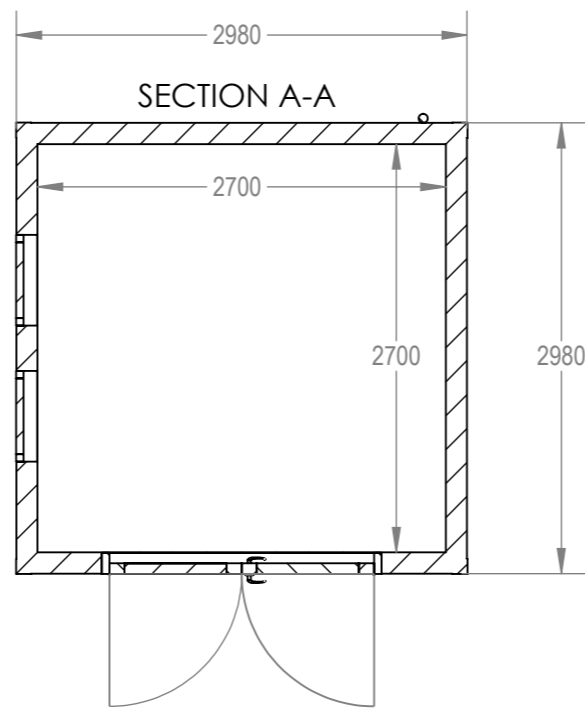

Red House Farm Business Units, Bacton, Suffolk, IP14 4LE
TEL. 01449 782 123 www.portablespace.co.uk

Copyright in this drawing belongs to Portable Space Ltd. Neither the whole drawing nor any part thereof may be reproduced without the prior written permission of Portable Space Ltd.

DESCRIPTION: COMO 3		QF NUMBER: QF-2001	
CONTAINER/UNIT TYPE: COMO COLLECTION		DRAWING NUMBER: 10-02001	Rev: 0
DRAWN BY	NAME J.M.	DATE 25/03/2024	UNLESS OTHERWISE SPECIFIED, DIMENSIONS ARE IN MILLIMETERS TOLERANCES (UNLESS OTHERWISE SPECIFIED): LINEAR = 0 +/- 1.5mm 0.0 +/- 0.5mm 0.00 +/- 0.25mm ANGULAR = 1deg
CHECKED	NAME M.D.	DATE 25/03/2024	
SCALE: 1:50		[DO NOT SCALE DRAWING]	WEIGHT: TBC
			A3 SHEET 1 OF 1