

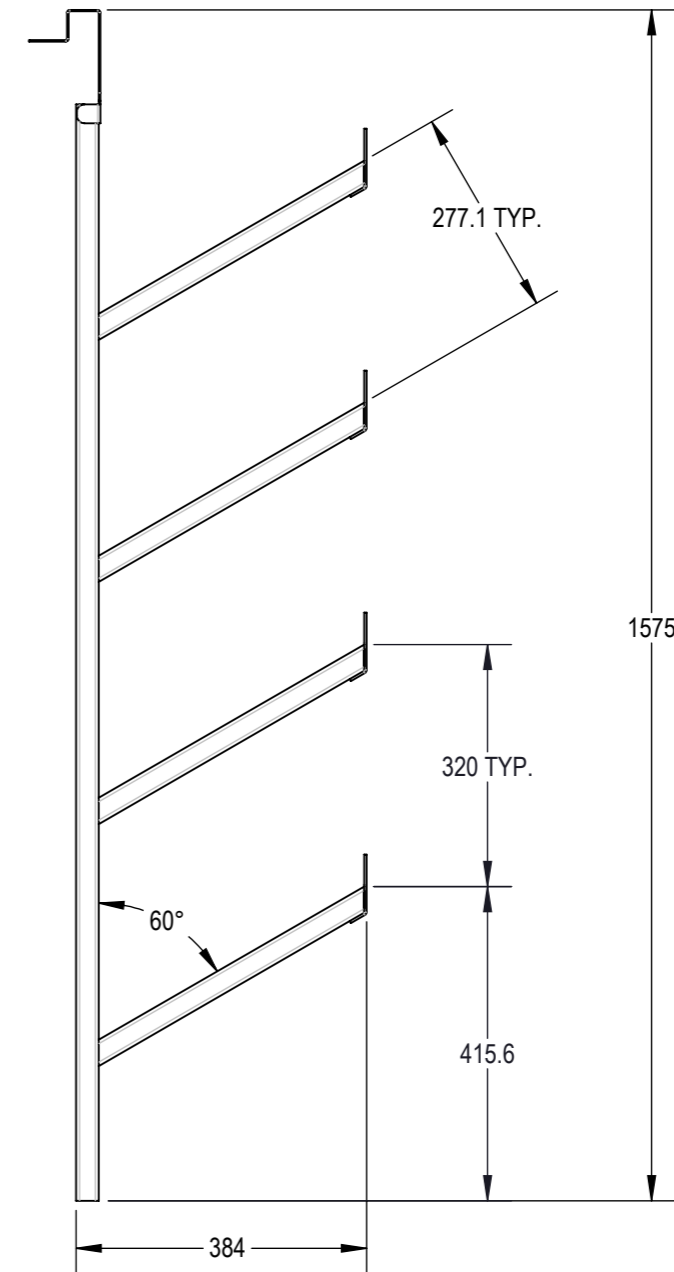



FITTED VIEW - UNIT NOT INCLUDED
[SCALE 1:25]



 cabin & container hire sales conversions modular	DESCRIPTION:		QF NUMBER:	
	INCLINED SHELVING BRACKETS		QF-511	
Modular House, Bacton Business Park, Suffolk, IP14 4LE TEL. 01449 782 123 www.portablespace.co.uk	CONTAINER/UNIT TYPE:		DRAWING NUMBER:	Rev:
	FLATPACK ACCESSORY		05-00511	0
Copyright in this drawing belongs to Portable Space Ltd. Neither the whole drawing nor any part thereof may be reproduced without the prior written permission of Portable Space Ltd.	NAME	DATE	UNLESS OTHERWISE SPECIFIED, DIMENSIONS ARE IN MILLIMETERS	
	DRAWN BY J.M.	28/01/25	TOLERANCES (UNLESS OTHERWISE SPECIFIED): LINEAR = 0 +/- 1.5mm 0.0 +/- 0.5mm 0.00 +/- 0.25mm ANGULAR = 1deg	
CHECKED	M.D.	28/01/2025	SCALE:1:10	WEIGHT: 12kg
			[DO NOT SCALE DRAWING]	A3 SHEET 1 OF 1