

ISO VIEW  
[SCALE 1:50]

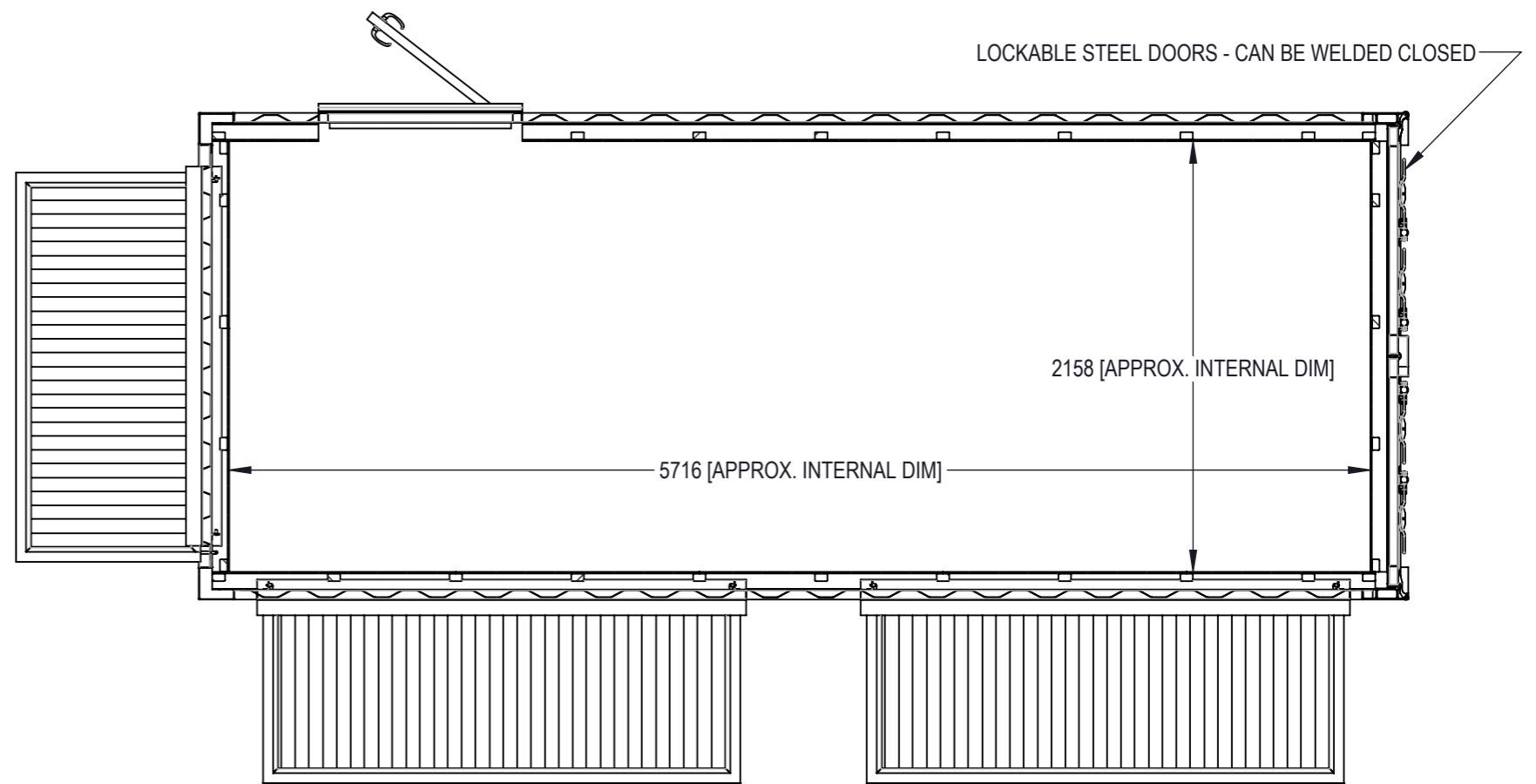

SECTION A-A  
SCALE 1 : 33

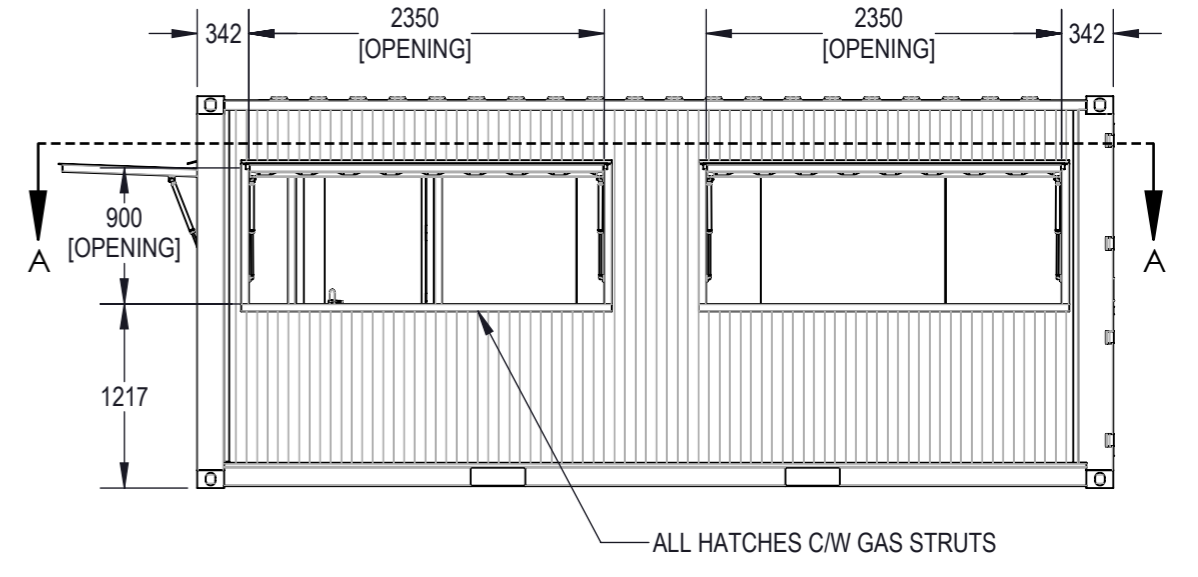
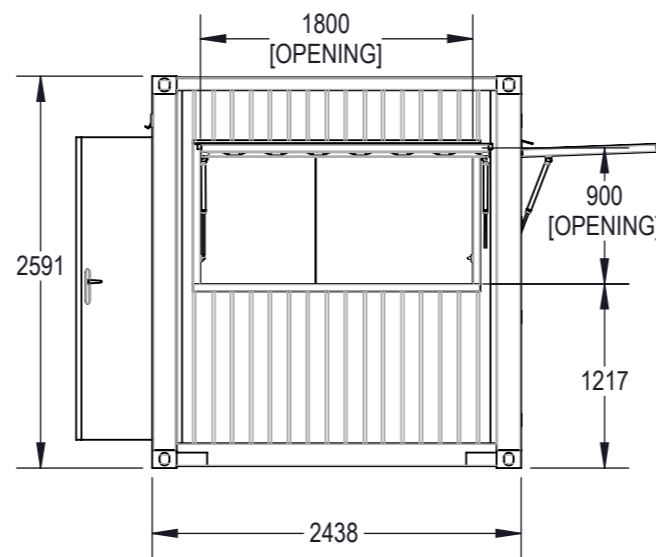
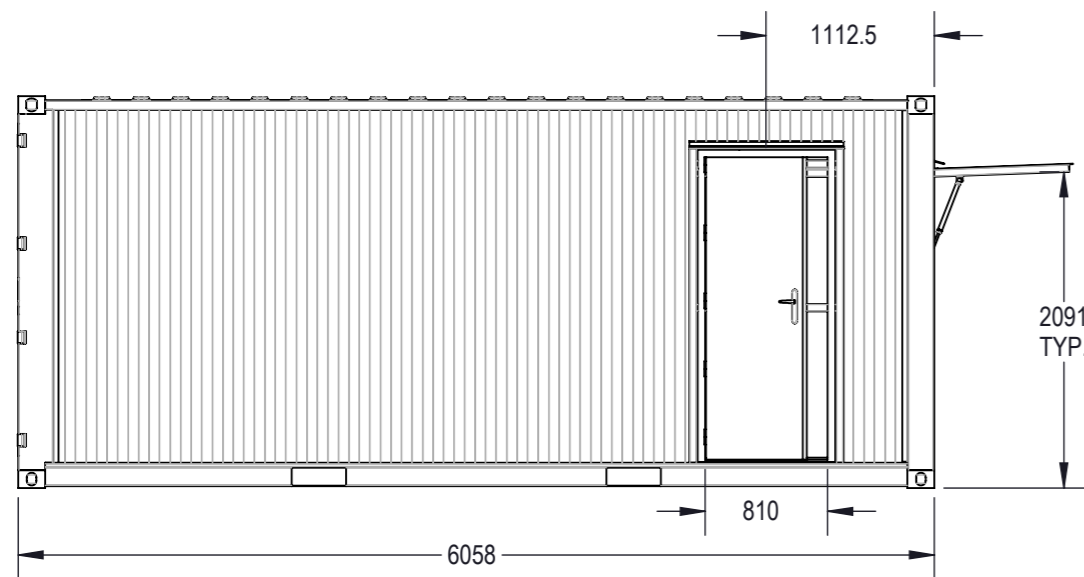

**BUILD NOTES:**

- PAINT EXTERNAL TO RAL [COLOUR TBC]
- APPLY GRAFO-THERM TREATMENT TO CEILING
- CEILING LINE OUT 100mm INSULATION AND 3.6mm POLYESTER COATED PLYBOARDS WITH MATCHING TRIM
- WALLS LINE OUT 50mm INSULATION AND 8mm MFC BOARDS
- OVERLAY EXISTING FLOOR WITH 5mm PLY AND 2mm NON-SLIP VINYL [COLOUR TBC]
- ELECTRICS NOT FITTED AS STANDARD

	Distribution Board/Consumer Unit		Wall Light Switch
	Panel Heater		Thermostat
	Tubular Panel Heater		Extraction Fan
	High Level Fan Heater		Smoke Sensor
	Water Heater - Under/Over Sink		Heat Sensor
	Waterproof LED Strip Light		Frost Stat
	Bulkhead Ceiling Light		RJ45 Data Point
	13A Socket-Above Counter		12mm Earthing Stud
	13A Socket - Below Counter		Fused Spur

**portablespace**<sup>®</sup>  
cabin & container hire | sales | conversions | modular

Modular House, Bacton Business Park, Suffolk, IP14 4LE  
TEL. 01449 782 123 www.portablespace.co.uk

Copyright in this drawing belongs to Portable Space Ltd. Neither the whole drawing nor any part thereof may be reproduced without the prior written permission of Portable Space Ltd.

DESCRIPTION: <b>20FT WEBSITE CAFÉ UNIT</b>		QF NUMBER: <b>QF-1200</b>	
CONTAINER/UNIT TYPE: <b>20FT ONE TRIP CONTAINER</b>		DRAWING NUMBER: <b>10-01200</b>	Rev: <b>A</b>
DRAWN BY	NAME	DATE	WEIGHT: <b>TBC</b>
CHECKED	A.U.	12/05/2025	
SCALE:1:50		[DO NOT SCALE DRAWING]	A3
UNLESS OTHERWISE SPECIFIED, DIMENSIONS ARE IN MILLIMETERS TOLERANCES (UNLESS OTHERWISE SPECIFIED): LINEAR = 0 +/- 1.5mm 0.0 +/- 0.5mm 0.00 +/- 0.25mm ANGULAR = 1deg		SHEET 1 OF 1	