

FLAT PACK OFFICE CABIN

2.3M INSTALLATION INSTRUCTIONS

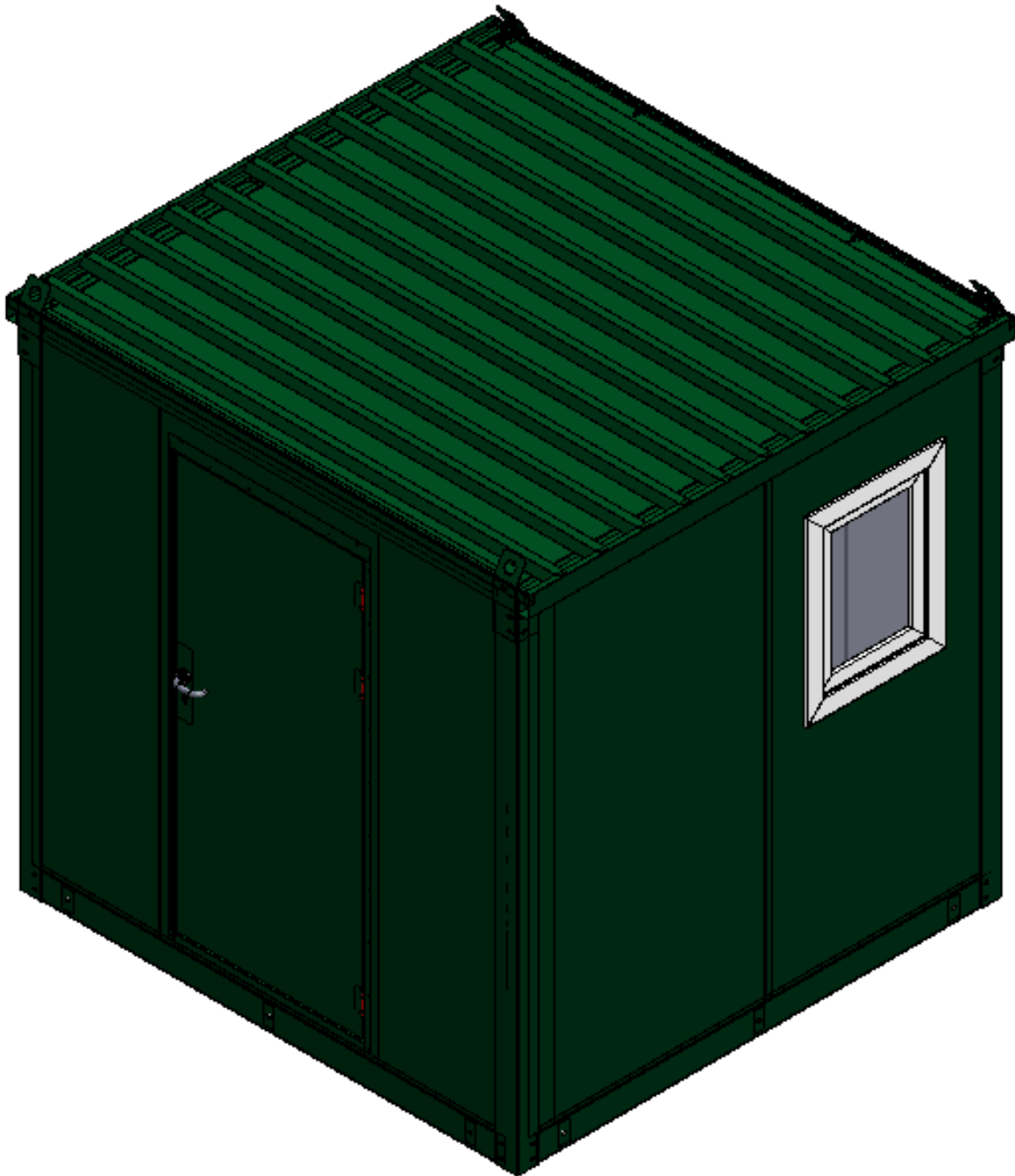

1. The chassis is placed on a flat surface.



2. First the inner corner profile is fixed to the chassis using bolts.

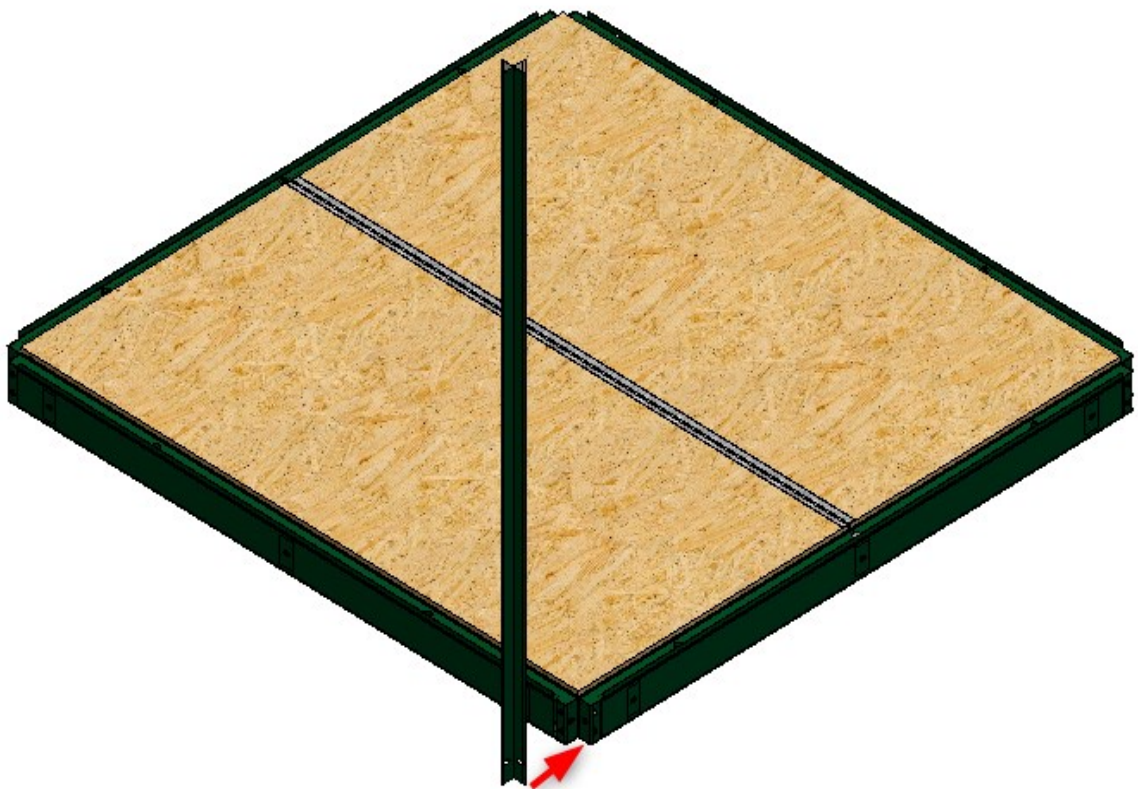

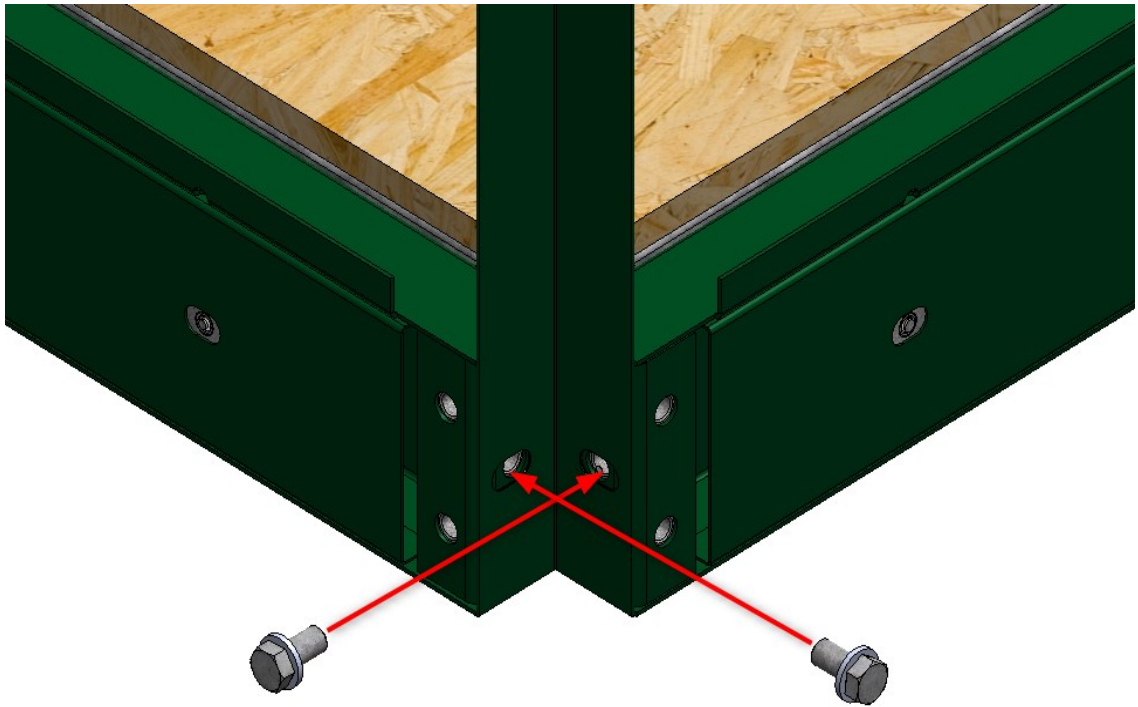

3. The outer corner profiles are also fixed to the chassis with bolts in the same way.

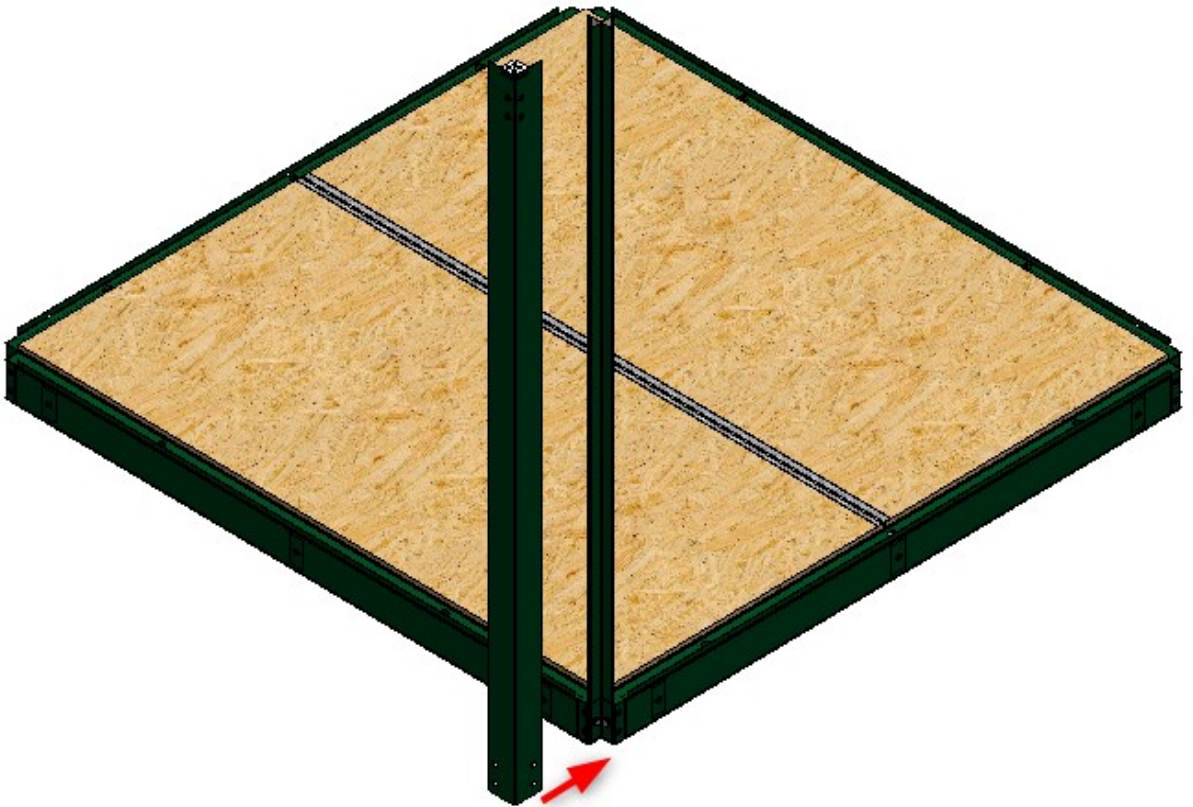

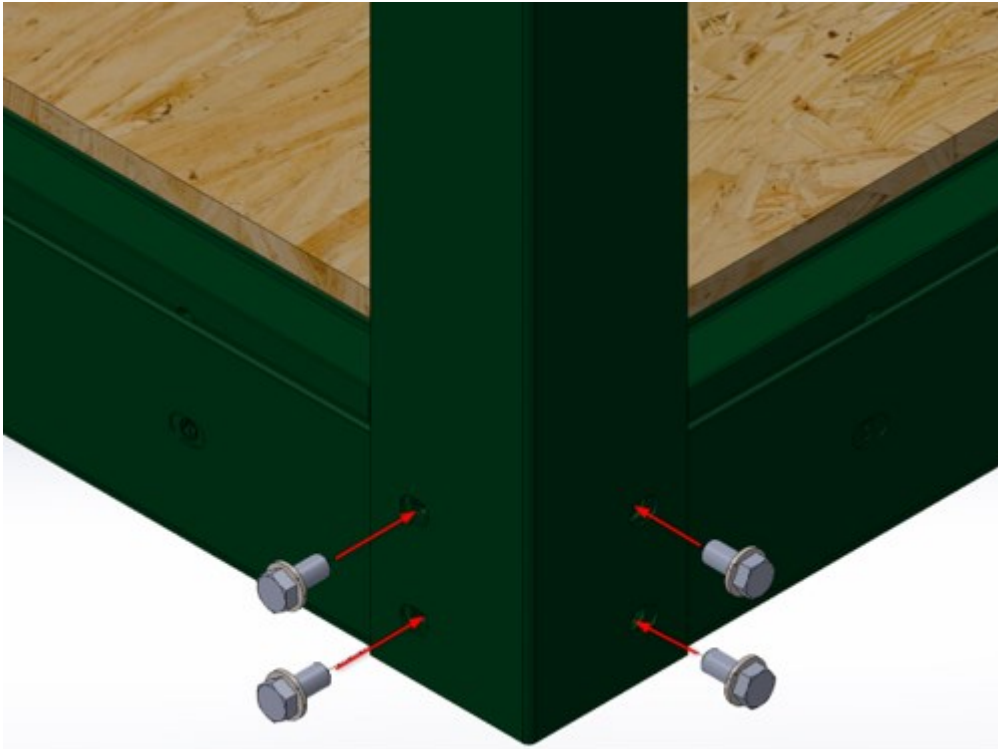

4. After the corner profiles are fixed, a 94 mm narroww panel is placed.

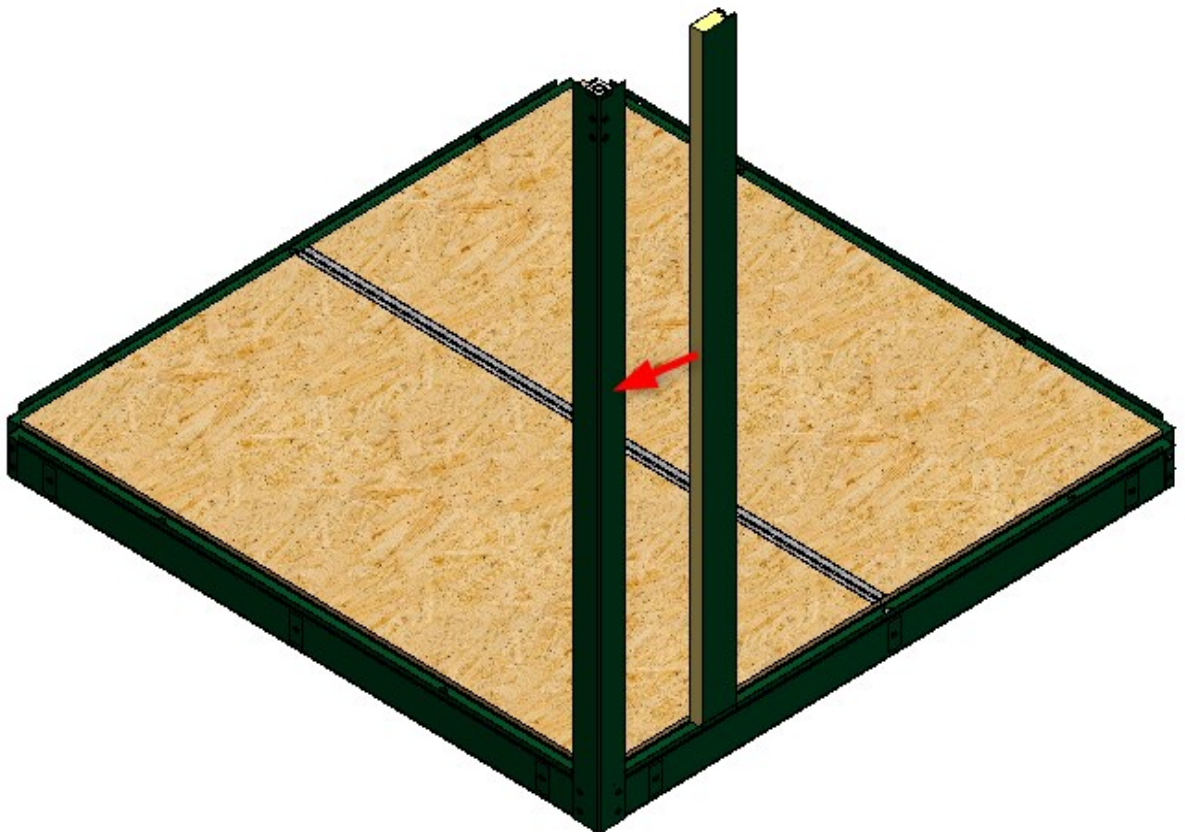

5. After the small panel, 2 full panels are placed. Window panels are used instead of any full panel.

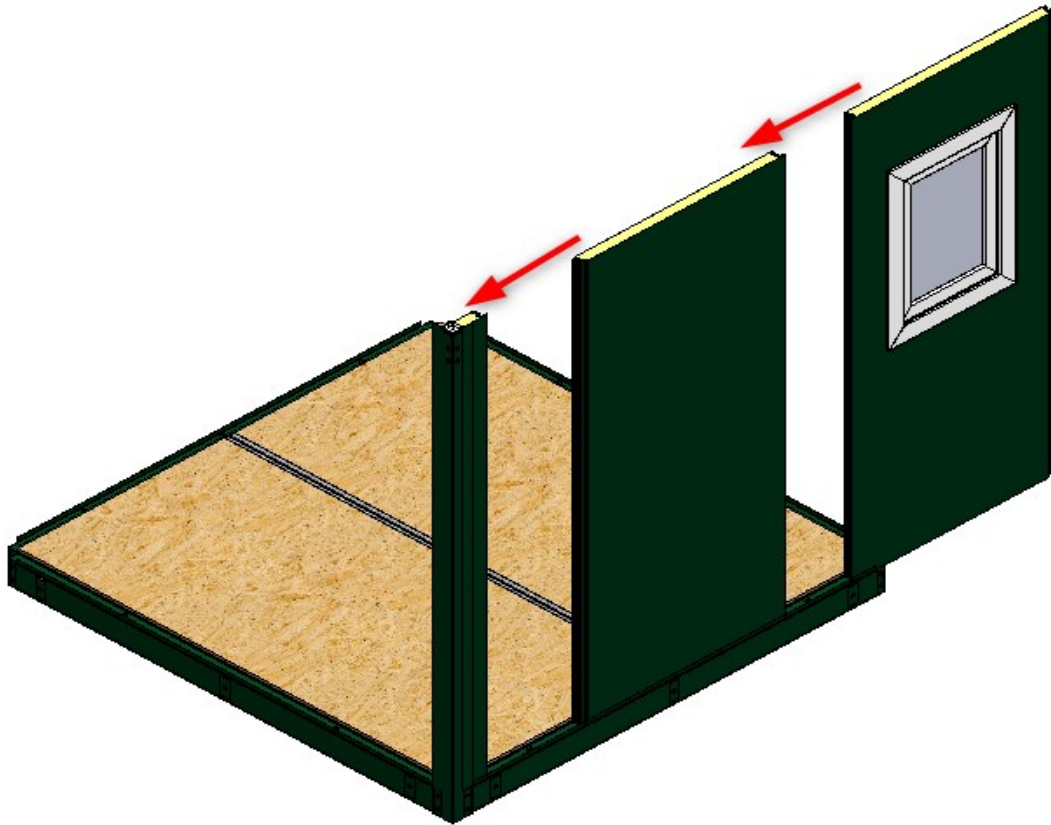

6. The side wall is completed by fixing the inner and outer corner profiles to the other end of the panel with bolts in the same order.

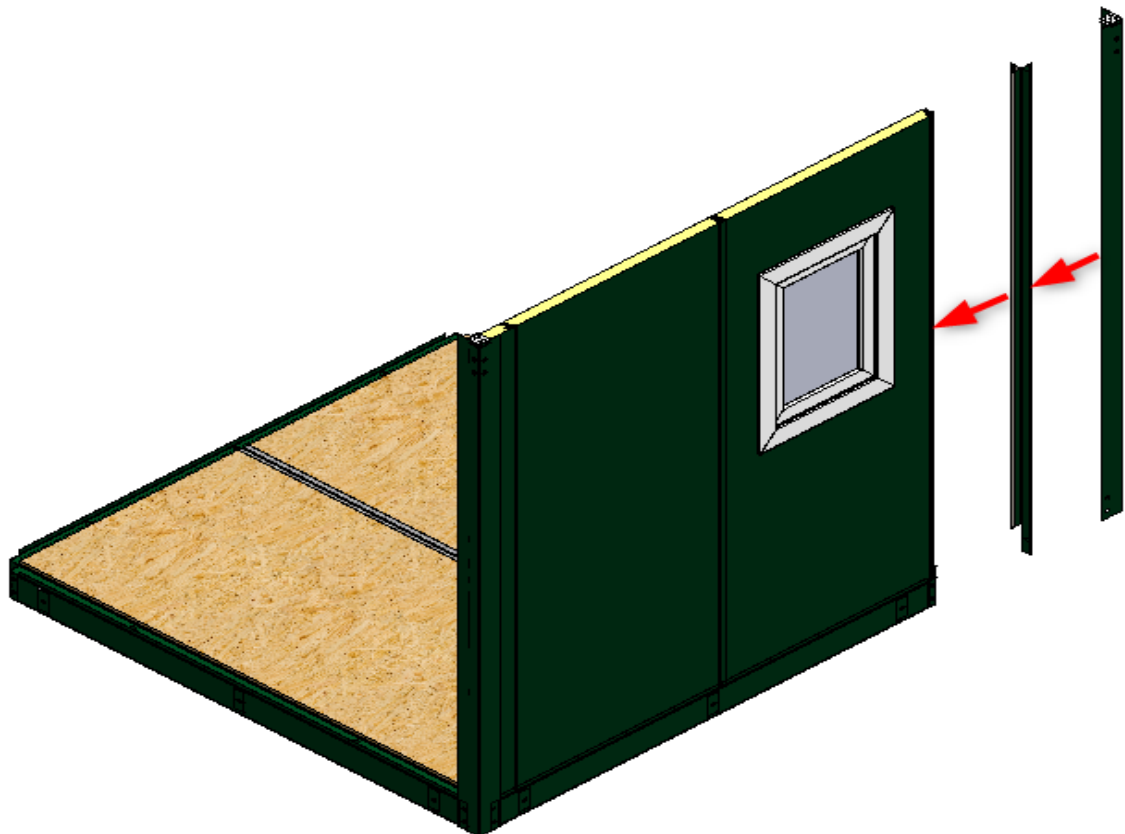

7. On the short side, 1 piece of 593 mm female and 1 piece of 593 mm male panel is used. The panel measuring 593 mm is placed next to the corner profile.

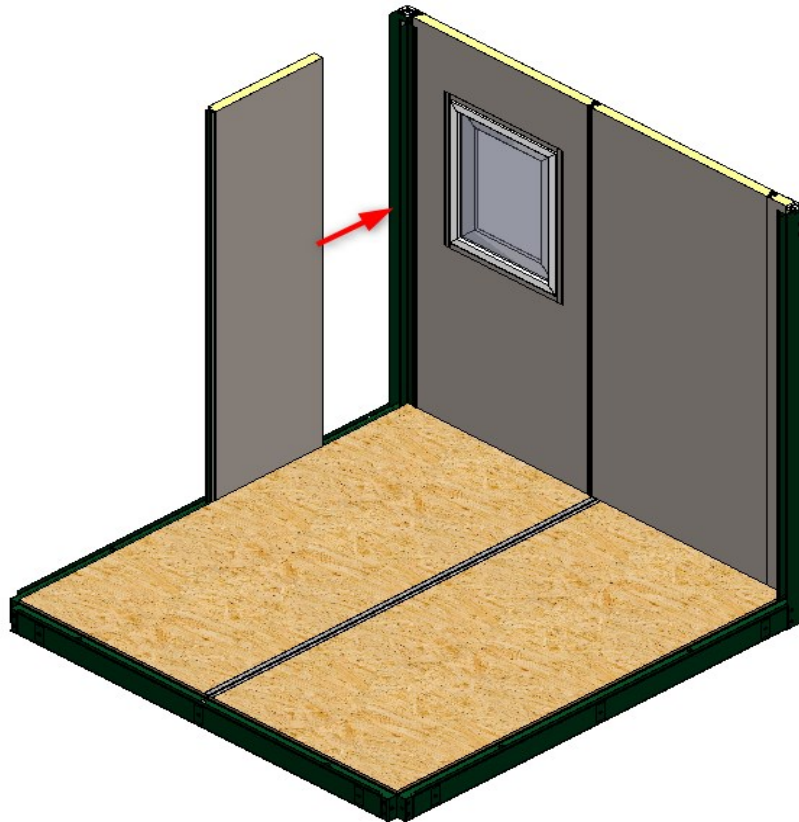

8. A full panel is used in the middle of the male and female panels measuring 593 mm.

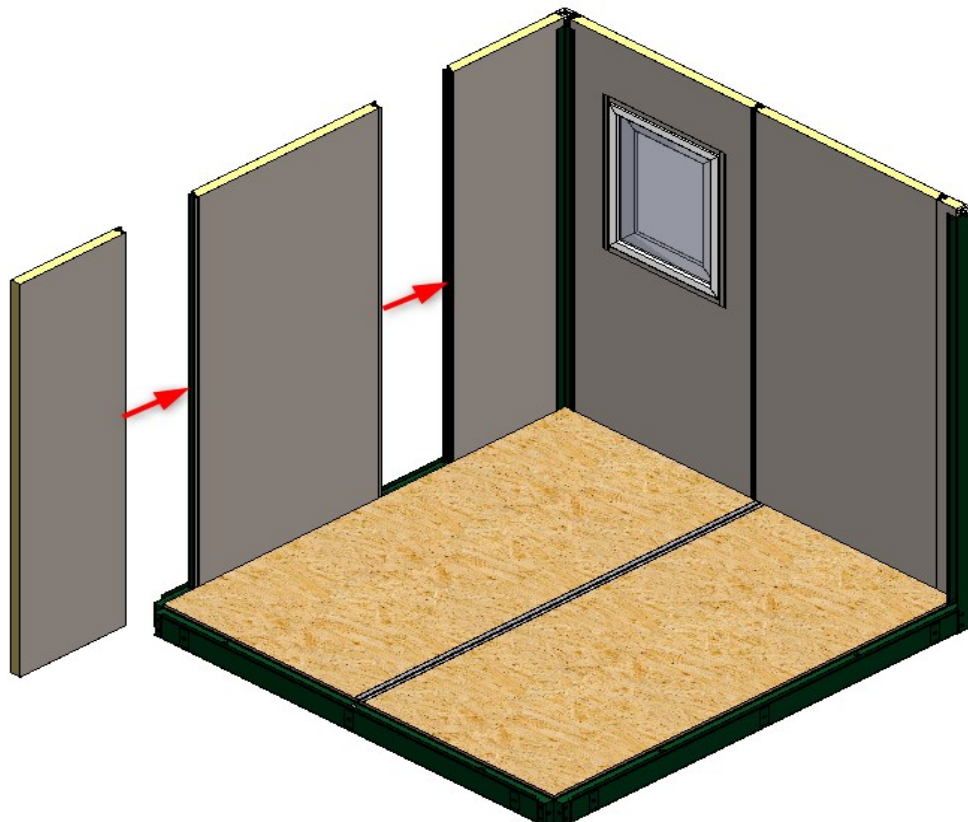

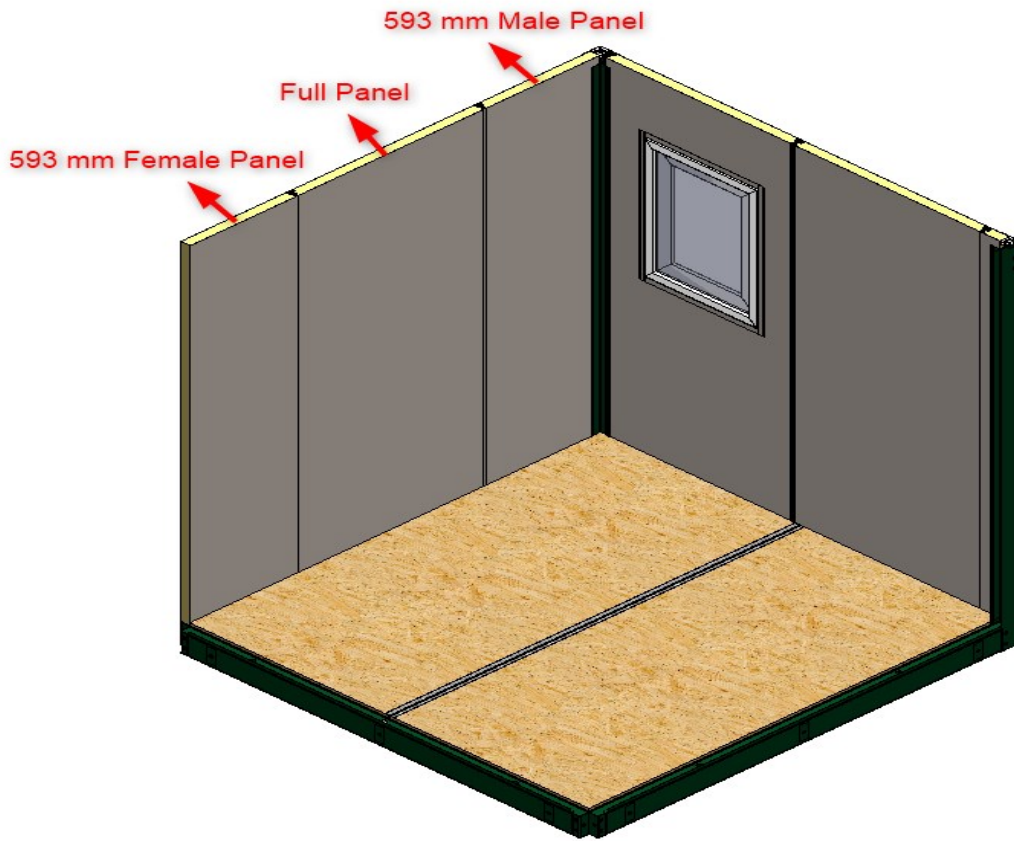

9. The short side is completed by mounting the corner profile and the panels of the other long side are placed. The length of the narrow panel is 124 mm.

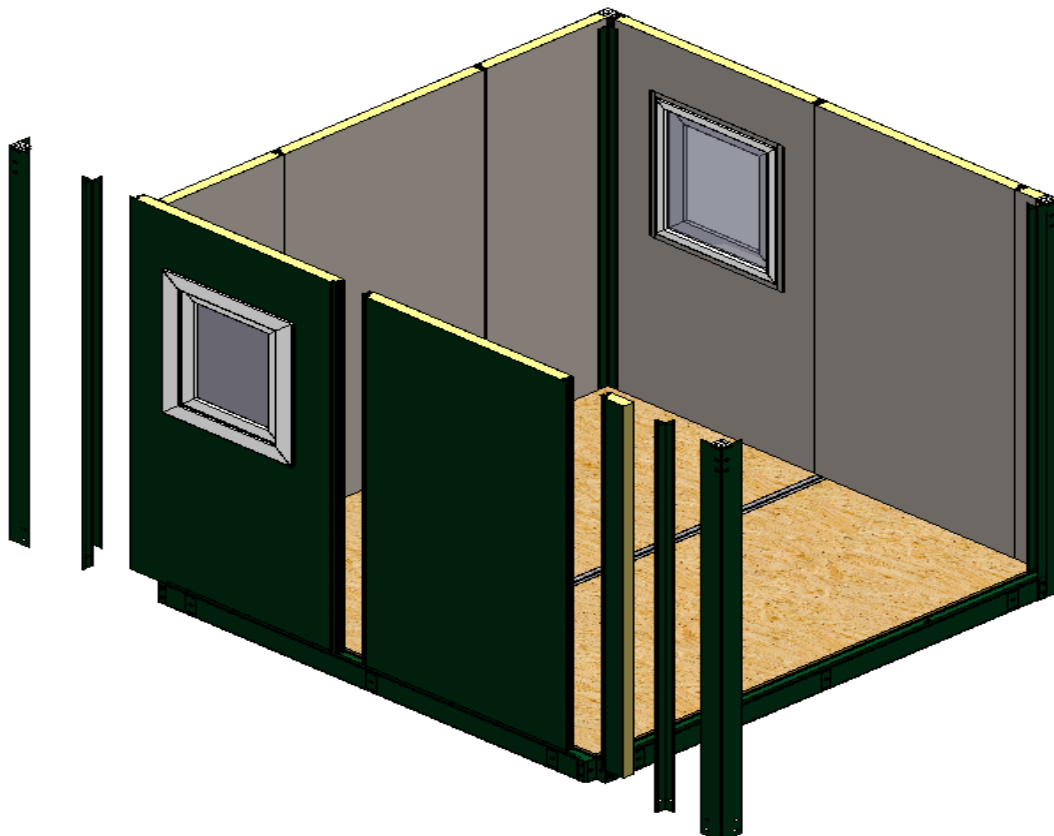

10. For the placement of the last edge; 1- 593 mm male panel 2- Door panel, the parts indicated with numbers are assembled as shown in the image.

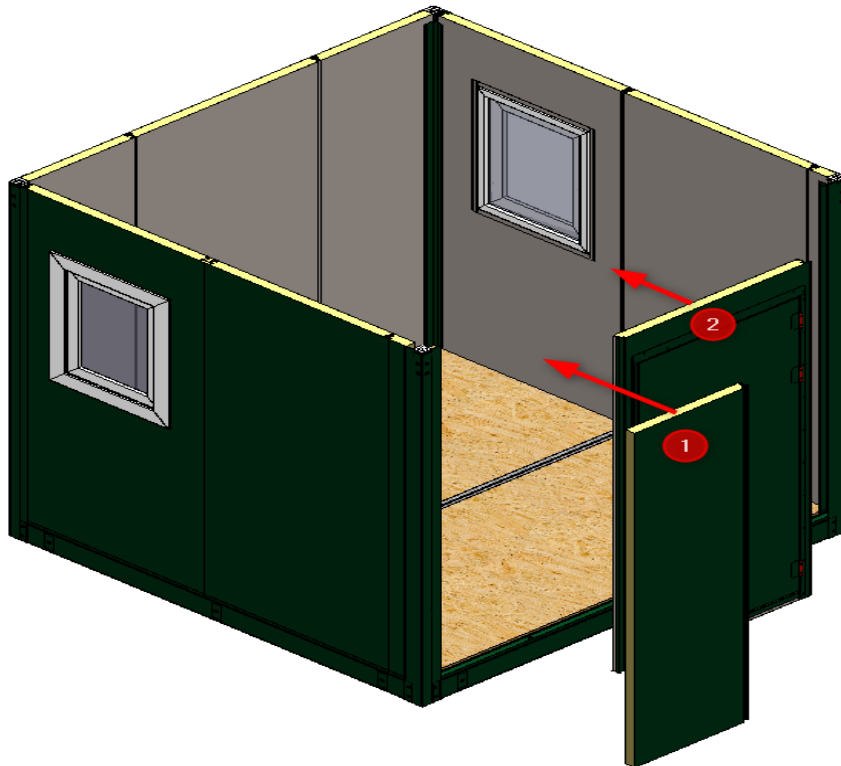

11. The 593 mm female panel is placed from top to bottom.

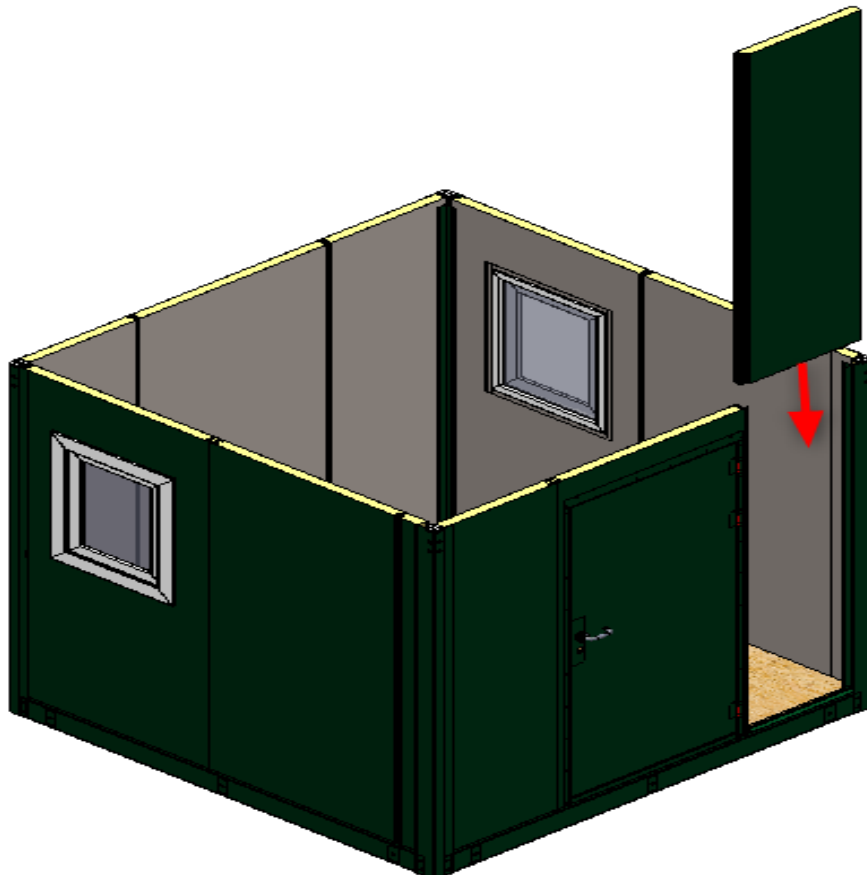

12. After panel placements are completed, u profiles are assembled with the help of pins.

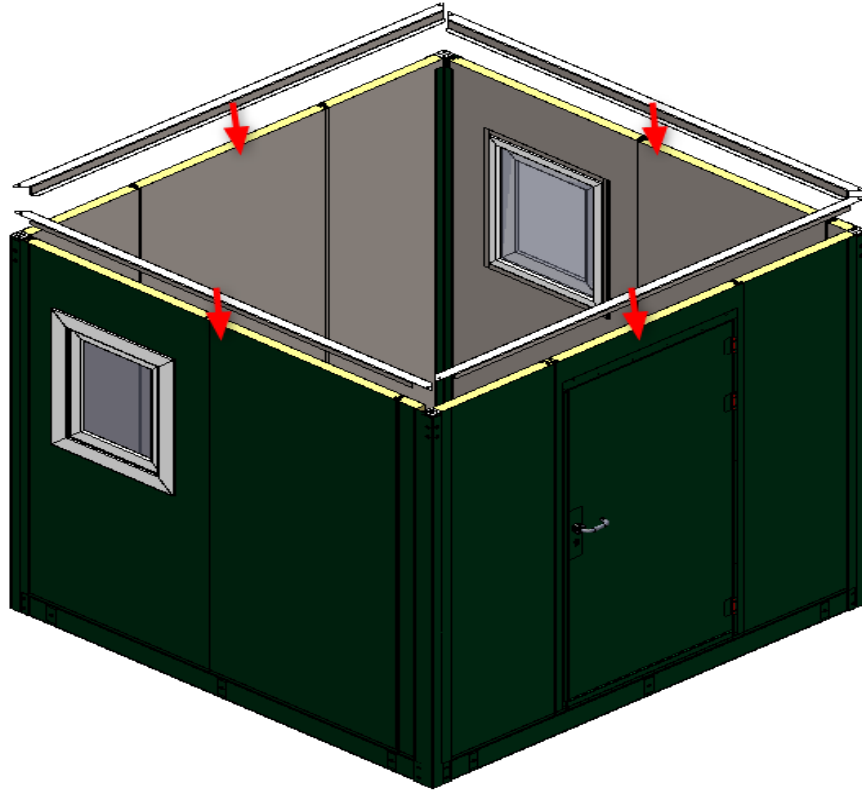

13. 2 full panels and 94 mm male panel are placed on U profiles.

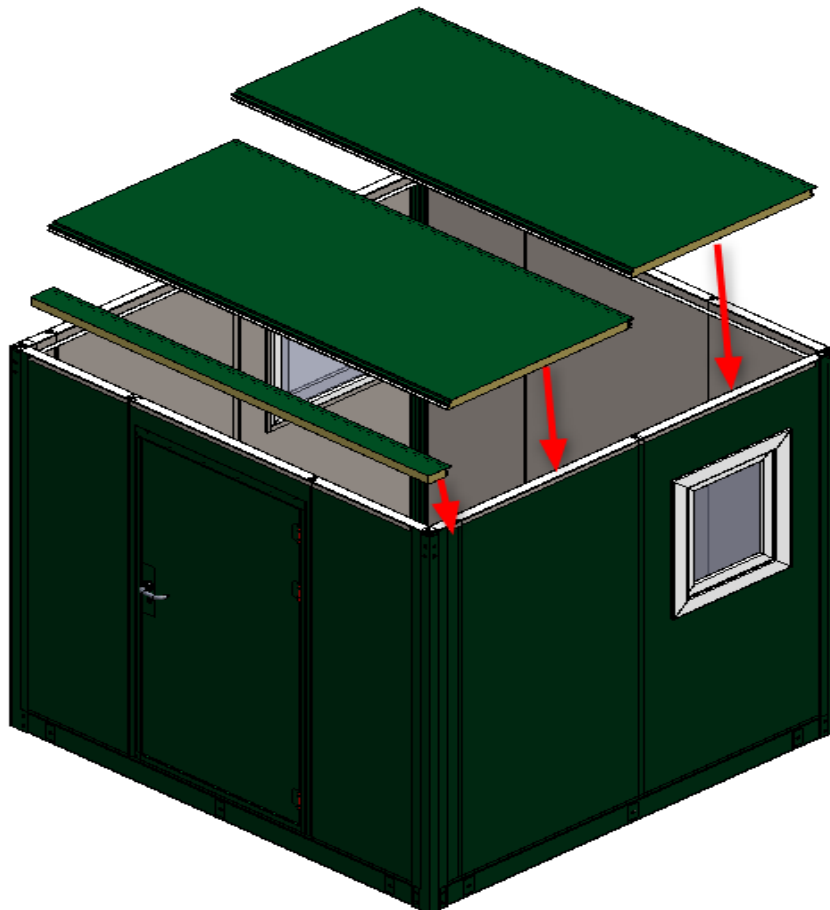

14. A metal sealed roof is placed on top of the sandwich panels on the roof side.

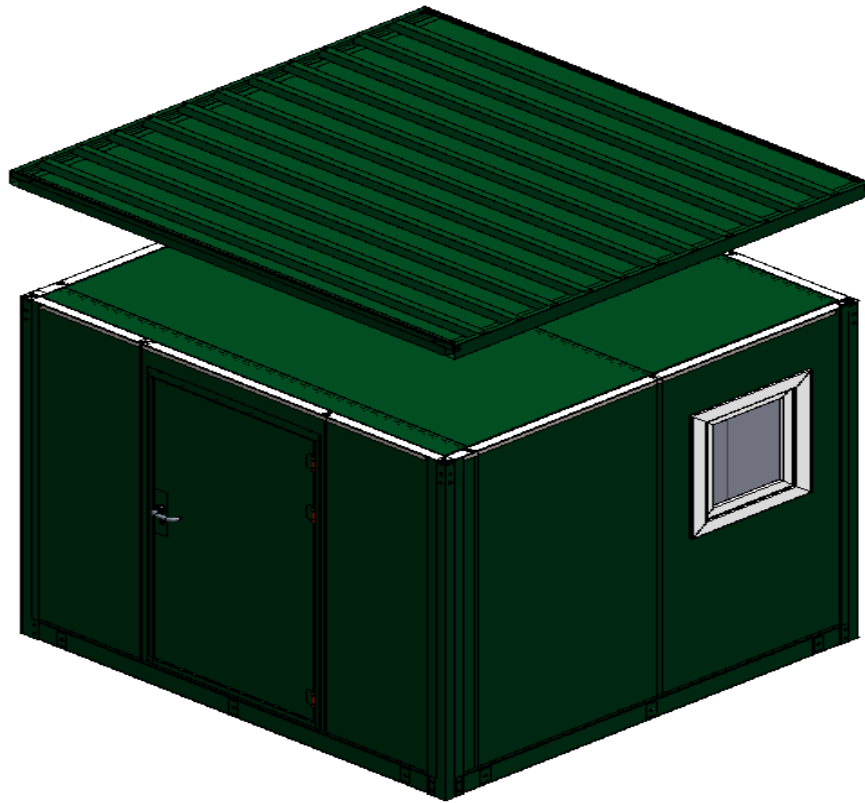

15. The lifting parts are fixed to the corner profiles and the roof with bolts. The roof is fixed to the product and allows it to be carried by crane. The product is ready to use.

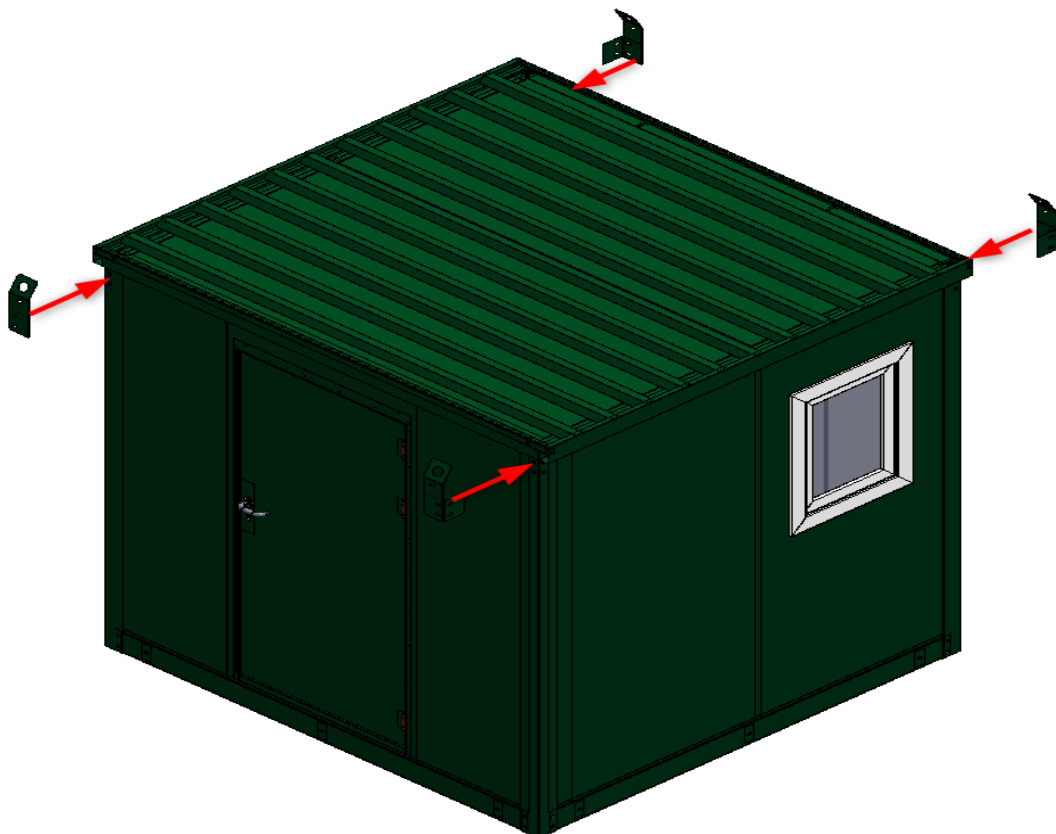

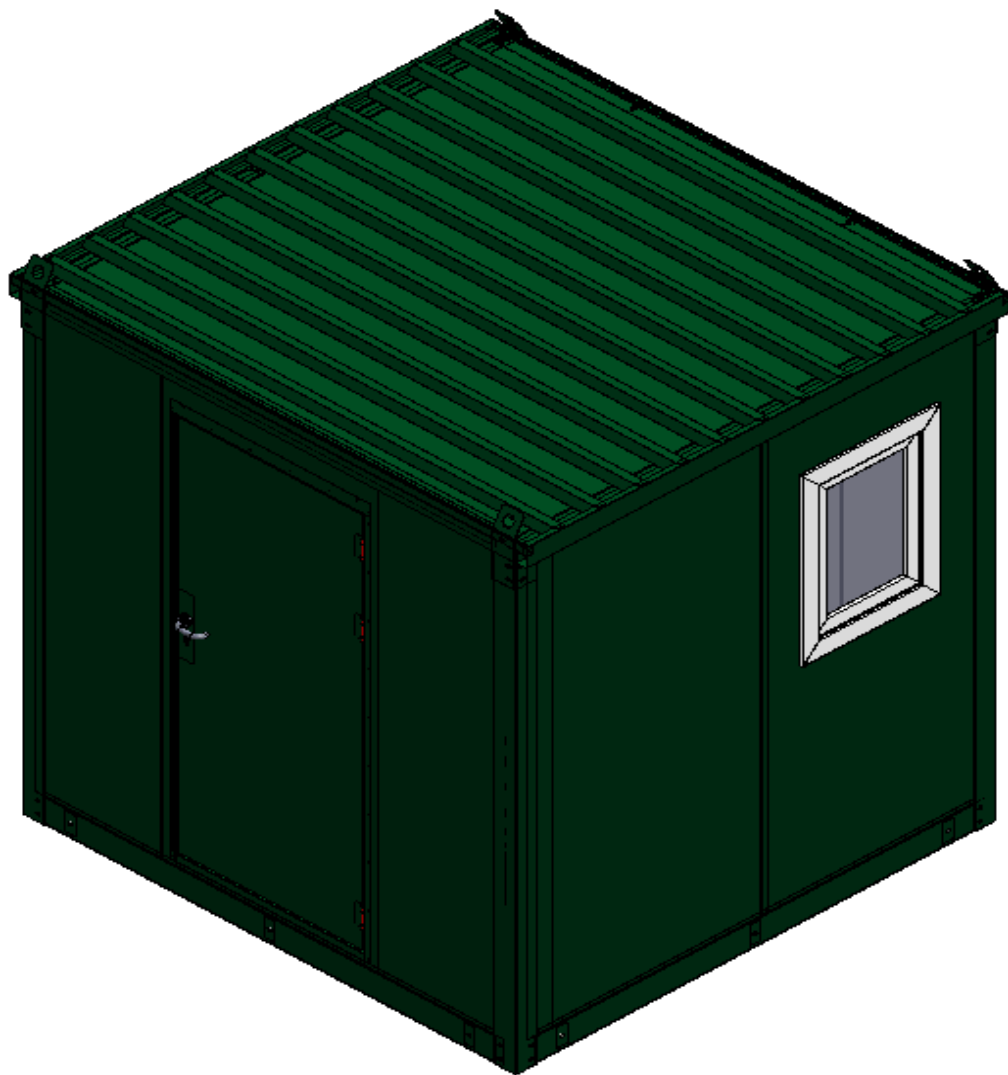
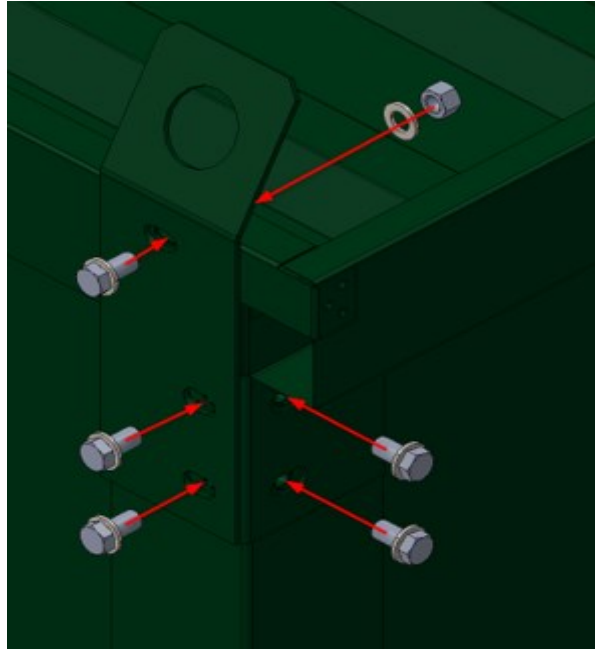

portable**space**[®]

cabin & container hire | sales | conversions | modular

Portable Space Ltd,
Modular House, Bacton Business Park,
Stowmarket, Suffolk, IP14 4LE

T: +44(0) 01449 782123
info@portablespace.co.uk
www.portablespace.co.uk